

**DIMENSIONS**

**No: S3SFU222030-00**

**MODEL: 80SFU21.5 & 80SFU22.2**

**30**

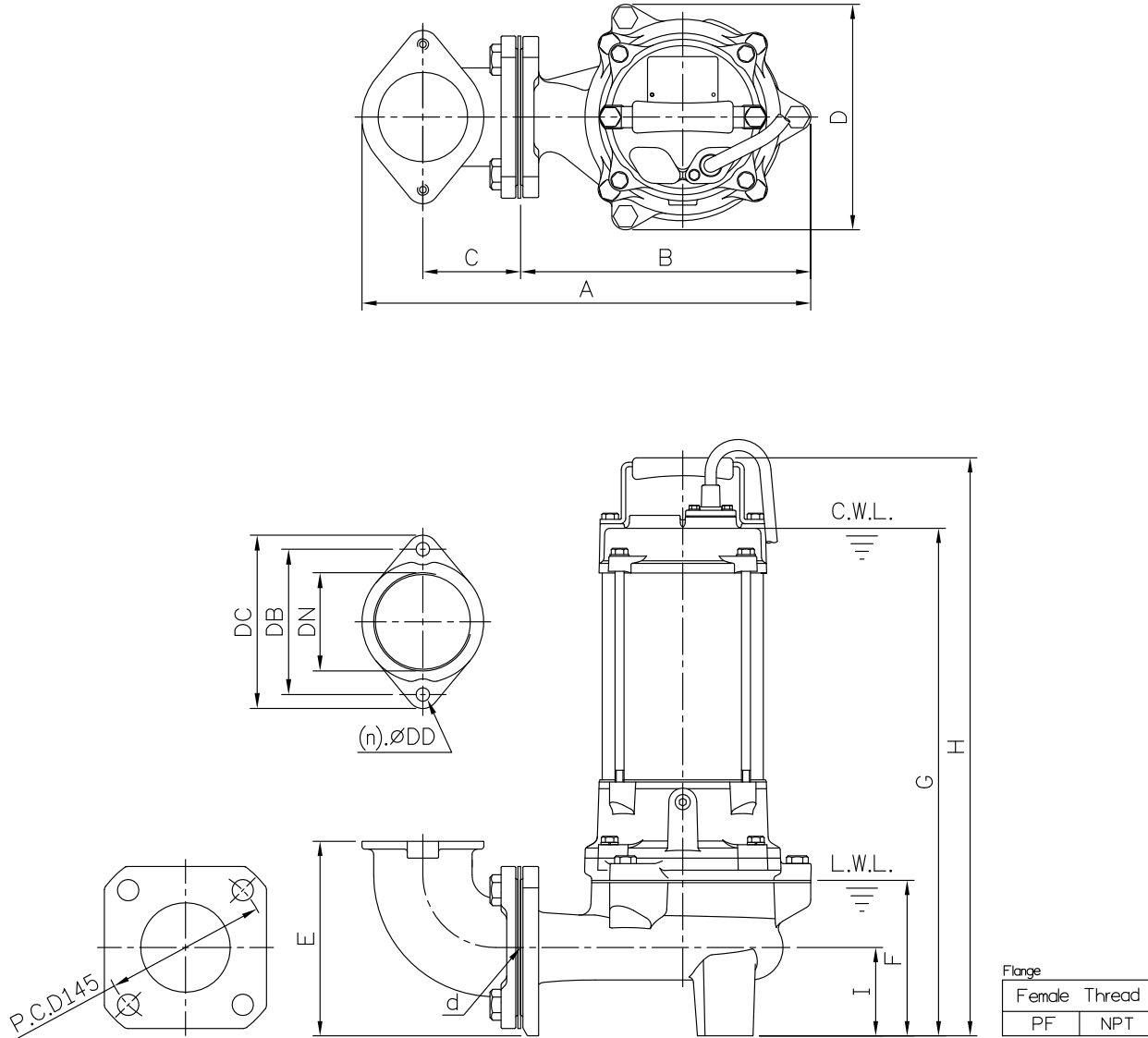

Dimensions—mm

Weight:Kg

Model	d	A	B	C	D	E	F	G	H	I	WT1 50Hz/60Hz	Elbow (Flange) Set	DN	DB	DC	DD	(n)QTY	WT2
80SFU21.5	80	402	260	88	202	174	139	454	517	79	27/26	ESB3-130K	80	130	155	12	2	4
80SFU22.2	80	402	260	88	202	174	139	454	517	79	29	ESB3-130K	80	130	155	12	2	4

Dimensions—inch

Weight:Lbs

Model	d	A	B	C	D	E	F	G	H	I	WT1 50Hz/60Hz	Elbow (Flange) Set	DN	DB	DC	DD	(n)QTY	WT2
80SFU21.5	3	15 <sup>3</sup> / <sub>16</sub>	10 <sup>1</sup> / <sub>4</sub>	3 <sup>1</sup> / <sub>16</sub>	7 <sup>15</sup> / <sub>16</sub>	6 <sup>7</sup> / <sub>8</sub>	5 <sup>1</sup> / <sub>2</sub>	17 <sup>7</sup> / <sub>8</sub>	20 <sup>3</sup> / <sub>8</sub>	3 <sup>1</sup> / <sub>8</sub>	60/57	ESB3-130K	3	5 <sup>1</sup> / <sub>8</sub>	6 <sup>1</sup> / <sub>8</sub>	1/2	2	9
80SFU22.2	3	15 <sup>3</sup> / <sub>16</sub>	10 <sup>1</sup> / <sub>4</sub>	3 <sup>1</sup> / <sub>16</sub>	7 <sup>15</sup> / <sub>16</sub>	6 <sup>7</sup> / <sub>8</sub>	5 <sup>1</sup> / <sub>2</sub>	17 <sup>7</sup> / <sub>8</sub>	20 <sup>3</sup> / <sub>8</sub>	3 <sup>1</sup> / <sub>8</sub>	64	ESB3-130K	3	5 <sup>1</sup> / <sub>8</sub>	6 <sup>1</sup> / <sub>8</sub>	1/2	2	9

C.W.L.:Continuous Running Water Level WT1:Pump Weight(Without Cable)  
L.W.L.:Lowest Running Water Level WT2:Elbow Set Weight