

DIMENSIONS

No: S3FNP237030-00

MODEL: FN-35P

3Ø

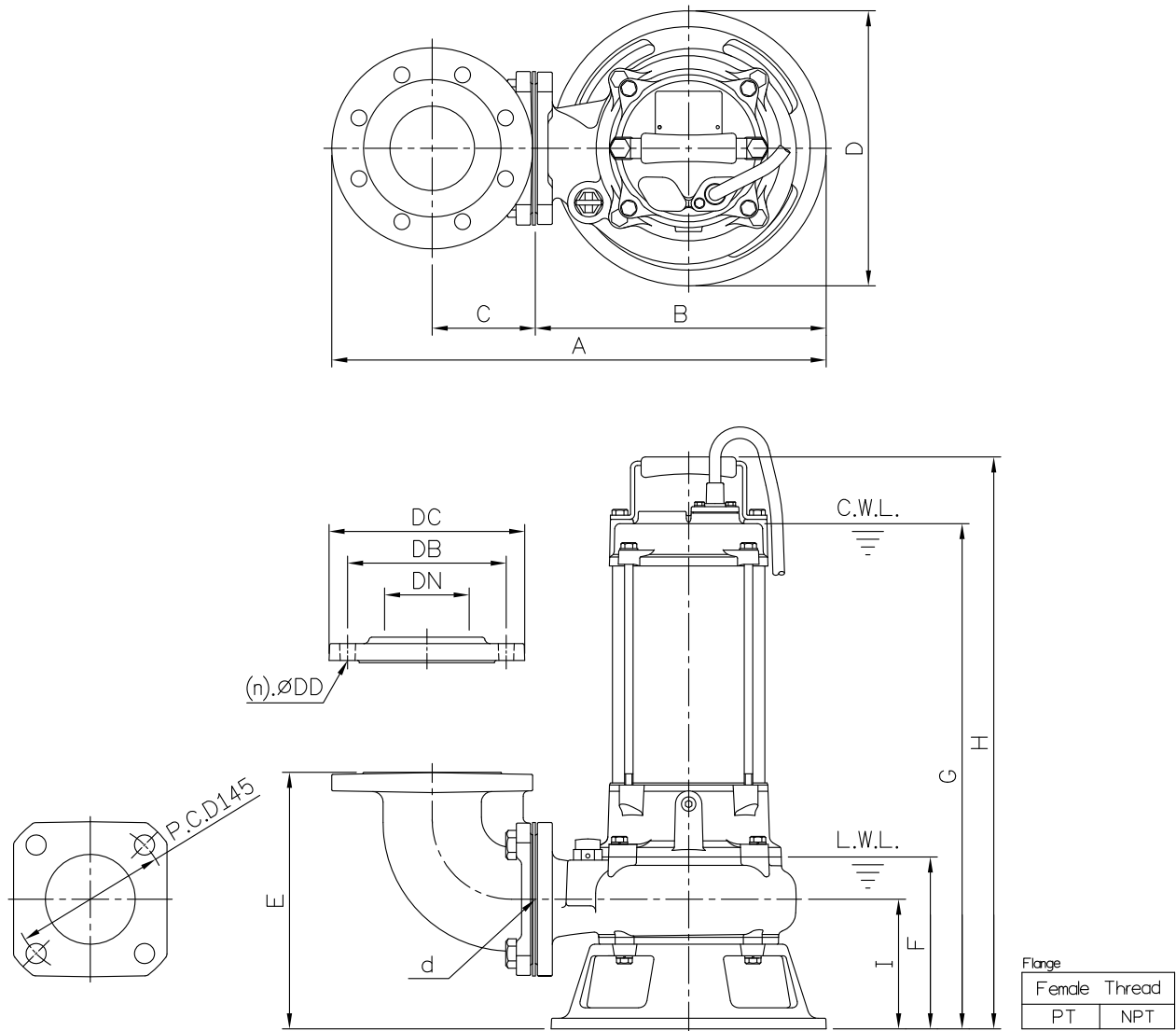

Dimensions—mm

Weight:Kg

| Model | d | A | B | C | D | E | F | G | H | I | WT1 | Elbow (Flange) Set | DN | DB | DC | DD | (n)QTY | WT2 |
|--------|----|-----|-----|----|-----|-----|-----|-----|-----|-----|-----|--------------------|----|-----|-----|----|--------|-----|
| FN-35P | 80 | 468 | 275 | 98 | 260 | 243 | 163 | 478 | 541 | 123 | 35 | EB3-150A | 80 | 150 | 185 | 15 | 8 | 12 |

Dimensions—inch

Weight:Lbs

| Model | d | A | B | C | D | E | F | G | H | I | WT1 | Elbow (Flange) Set | DN | DB | DC | DD | (n)QTY | WT2 |
|--------|---|---------------------------------|---------------------------------|-------------------------------|--------------------------------|--------------------------------|--------------------------------|----------------------------------|---------------------------------|--------------------------------|-----|--------------------|----|-------------------------------|--------------------------------|--------------------------------|--------|-----|
| FN-35P | 3 | 18 ³ / ₁₆ | 10 ³ / ₁₆ | 3 ⁷ / ₈ | 10 ¹ / ₄ | 9 ⁹ / ₁₆ | 6 ⁷ / ₁₆ | 18 ¹³ / ₁₆ | 21 ⁵ / ₁₆ | 4 ¹ / ₁₆ | 77 | EB3-150A | 3 | 5 ⁷ / ₈ | 7 ⁵ / ₁₆ | 3 ¹ / ₁₆ | 8 | 26 |

C.W.L.:Continuous Running Water Level WT1:Pump Weight(Without Cable)
 L.W.L.:Lowest Running Water Level WT2:Elbow Set Weight